

CHAINS FOR SPECIAL APPLICATIONS – AUTOMOTIVE INDUSTRY

PENDULUM CHAINS

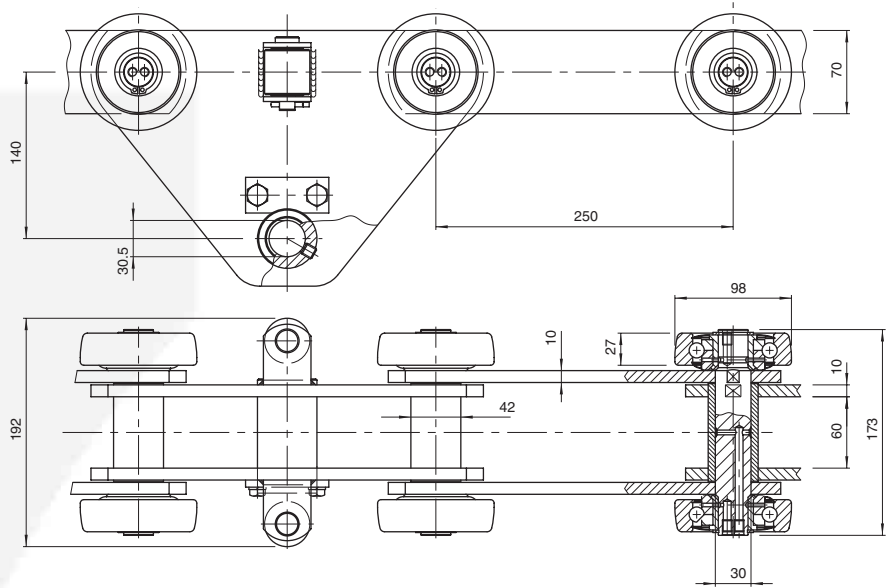

Chain P. 250x60x42 øB



Breaking load: 370.000 N

PENDULUM CHAINS

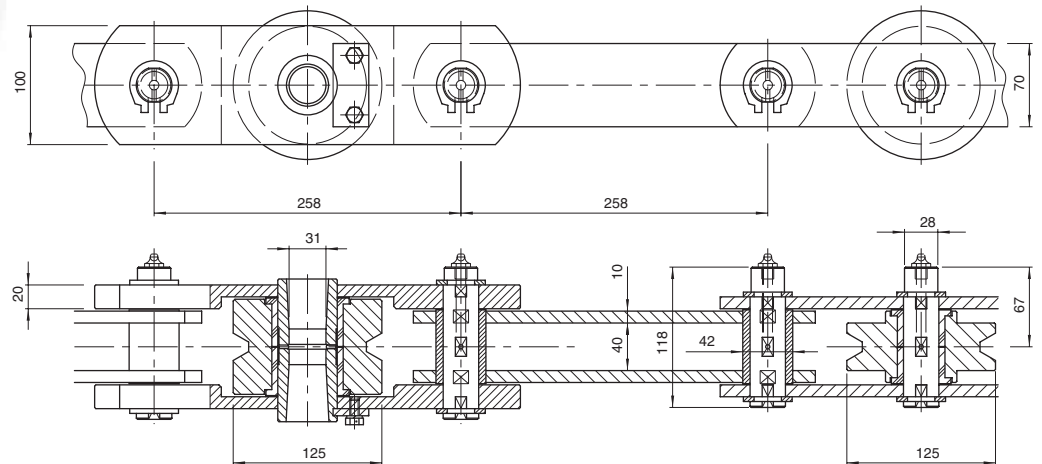

Chain P. 258x40x42 øB



Breaking load: 405.000 N

CHAINS FOR SPECIAL APPLICATIONS – AUTOMOTIVE INDUSTRY

PENDULUM CHAINS

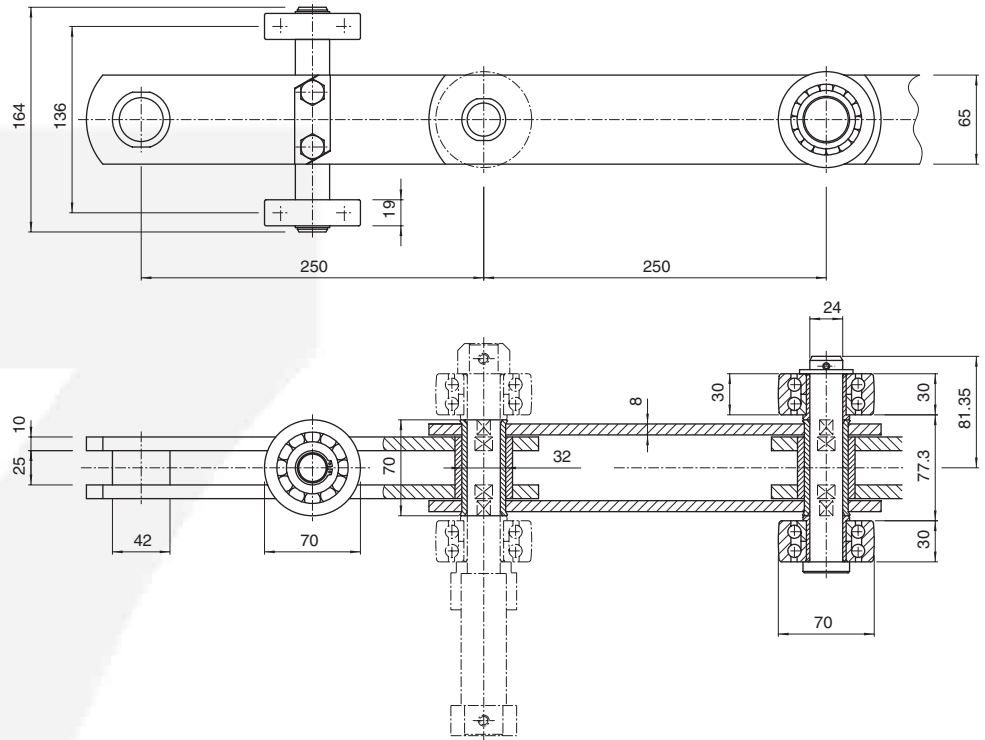

Chain P. 250x25x42 øB

 Breaking load: 380.000 N

PENDULUM CHAINS

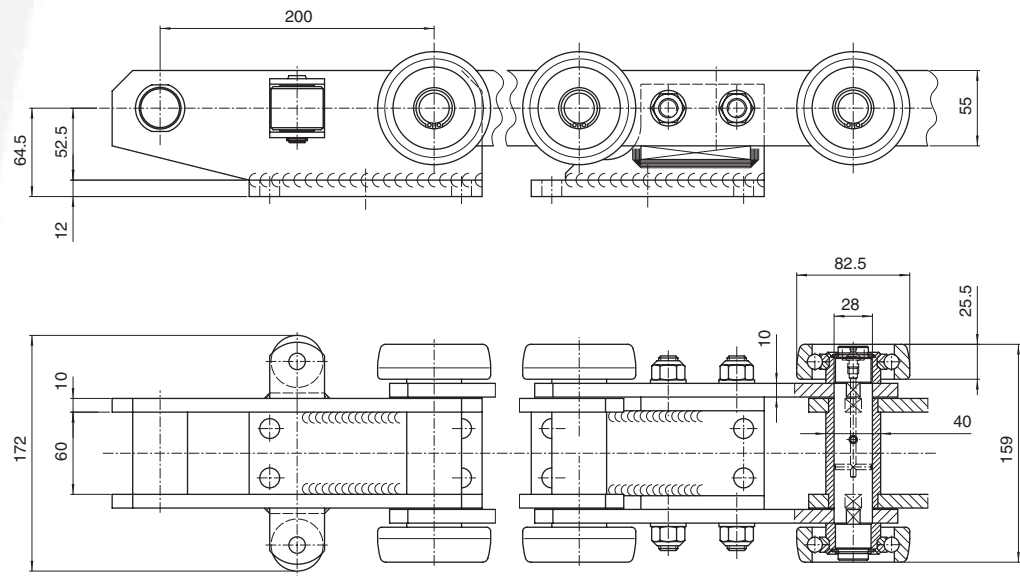

Chain P. 200x60x40 øB

 Breaking load: 300.000 N

CHAINS FOR SPECIAL APPLICATIONS – AUTOMOTIVE INDUSTRY

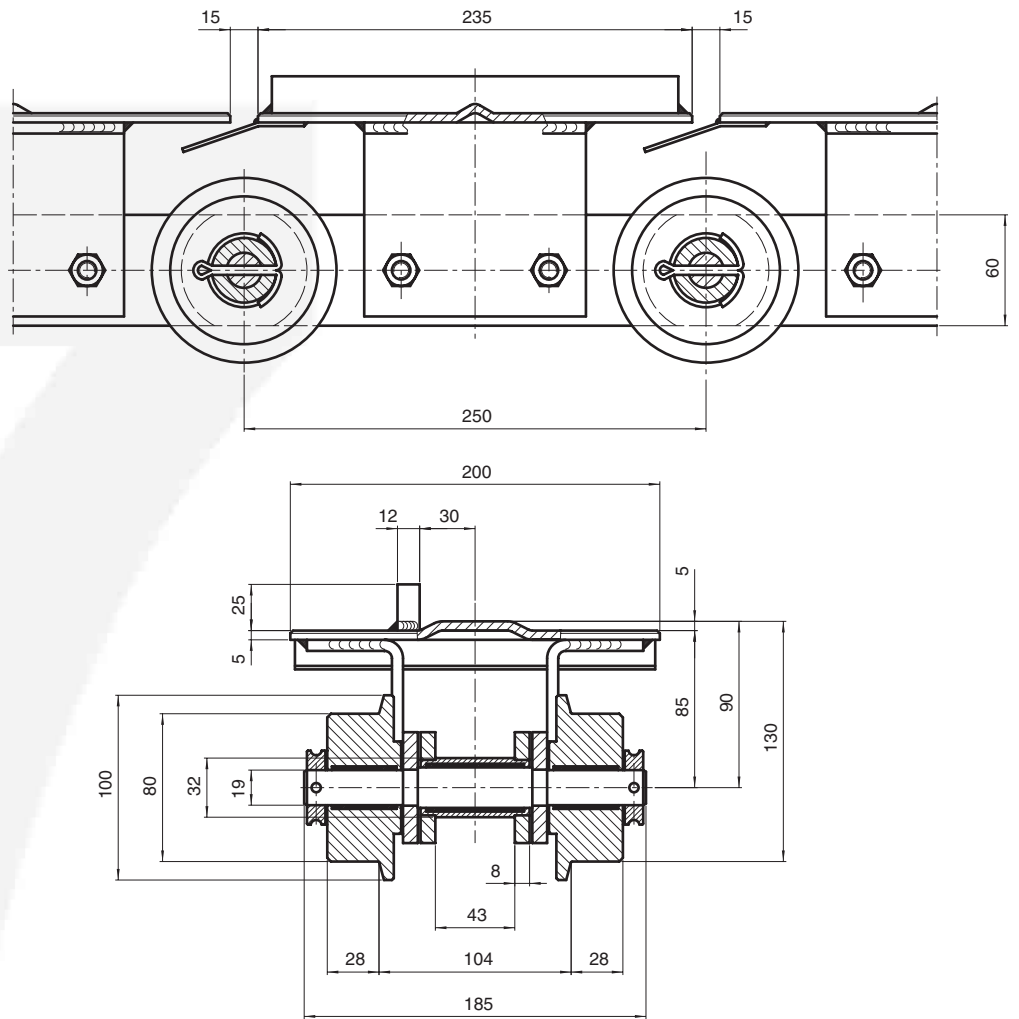

DRYING
OVENS

Chain P. 250x43x32 øB



Breaking load: 224.000 N

Lubrication and maintenance free
through MECASEC®
(registered trade mark by P.T.F.E. Sarl)



CHAINS FOR SPECIAL APPLICATIONS – AUTOMOTIVE INDUSTRY

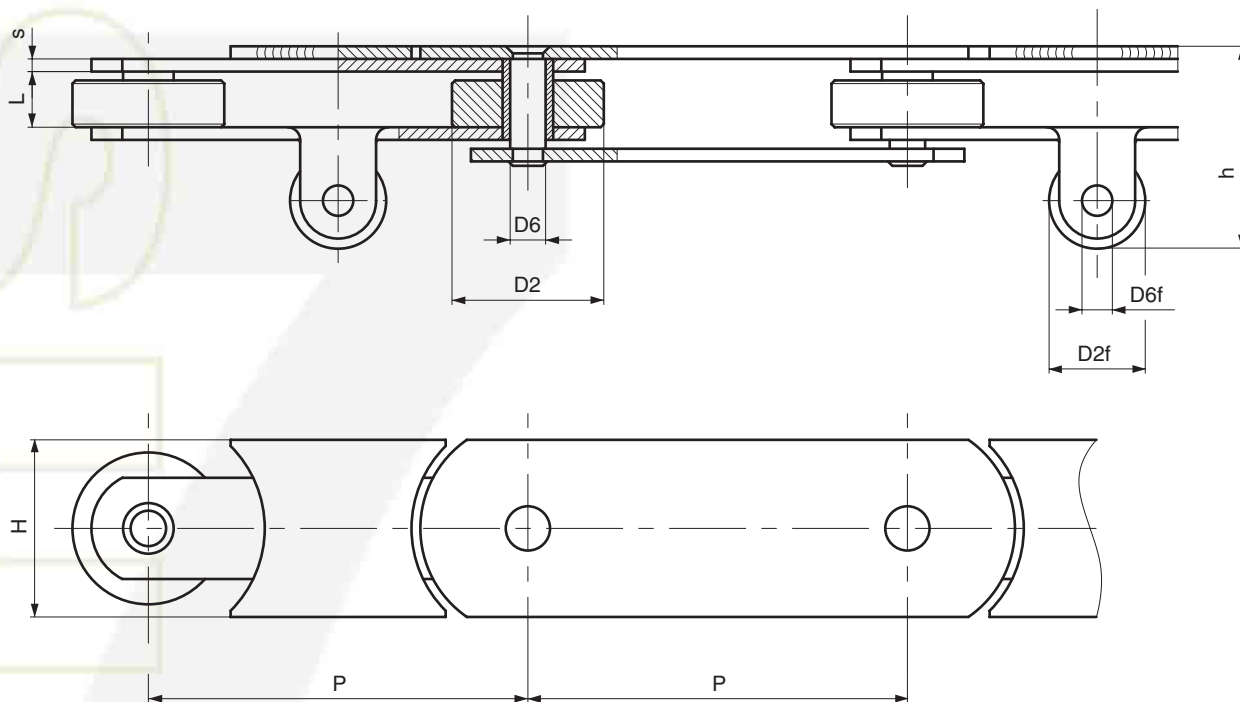

SKID CONVEYORS

Chain N.	P mm	L mm	D2 mm	D6 mm	H mm	S mm	D2f mm	D6f mm	h mm	Breaking load N
W4697	100	22	60	14	70	5	38	12	81	160.000
W2527R	150	22	60	14	70	5	38	12	81	160.000
W2542R	150	22	60	22	80	8	70	18	131	220.000
W4028R	150	22	60	14	100	5	38	12	81	160.000
W2595R	150	22	60	14	80	5	38	12	81	160.000

CHAINS FOR SPECIAL APPLICATIONS – AUTOMOTIVE INDUSTRY

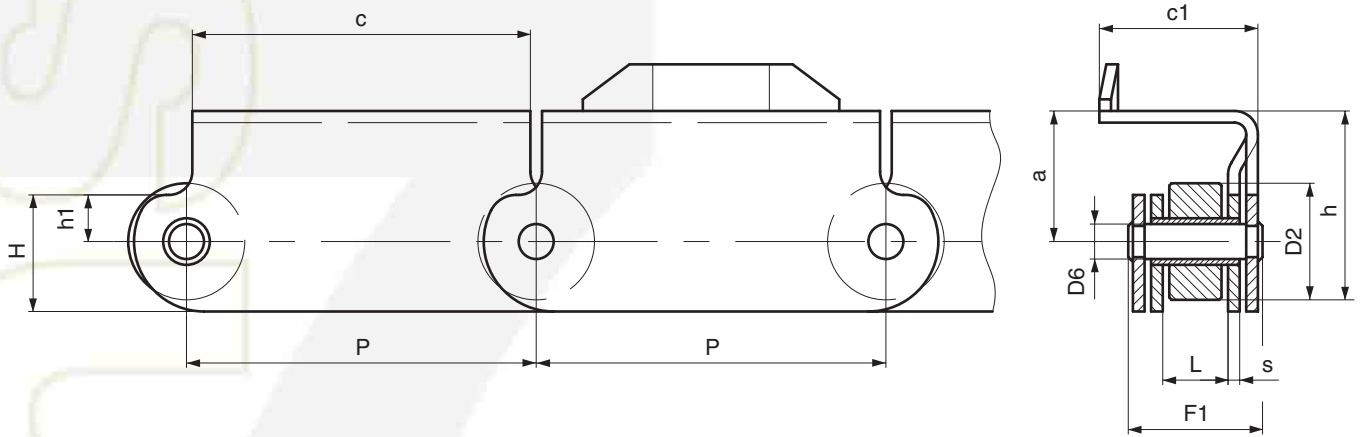

SKID CONVEYORS

Chain N.	P mm	L mm	D2 mm	D6 mm	H mm	h mm	h1 mm	S mm	F1 mm	a mm	c mm	c1 mm	Breaking load N
W2359	150	28	50	15	50	81	20	5	55	56	145	68	160.000
W3057	150	28	50	15	50	85	20	5	55	60	145	65	160.000
W3349	150	32	50	14	55	81	20	5	58,5	56	145	80	160.000
W2387	150	32	50	14	55	81	20	6	63	56	145	80	160.000

CHAINS FOR SPECIAL APPLICATIONS – AUTOMOTIVE INDUSTRY

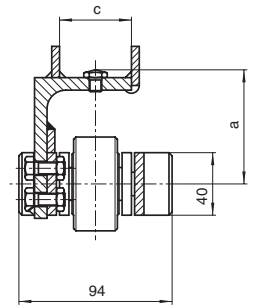
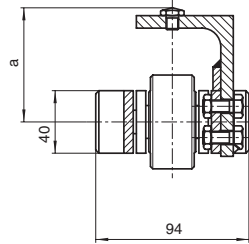
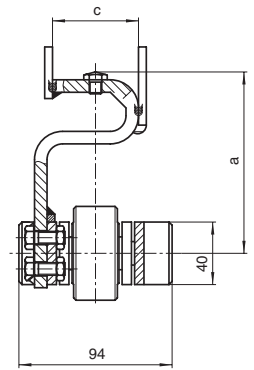
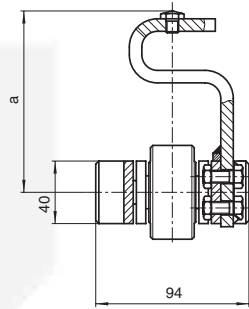
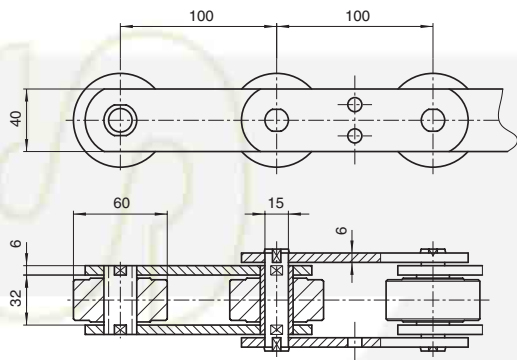

SKID
CONVEYORS

Chain P. 100x32x60 øR

 Breaking load: 112.000 N

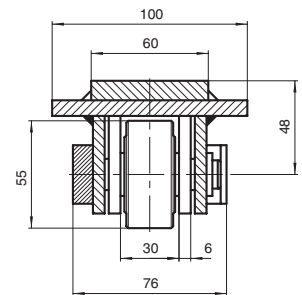
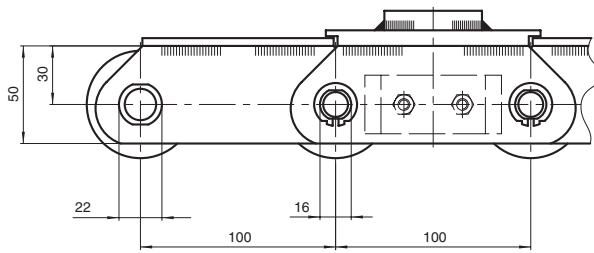
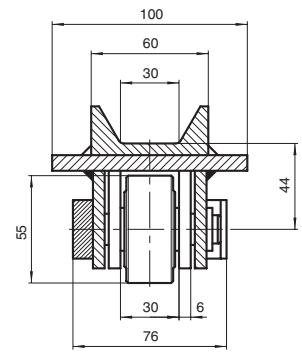
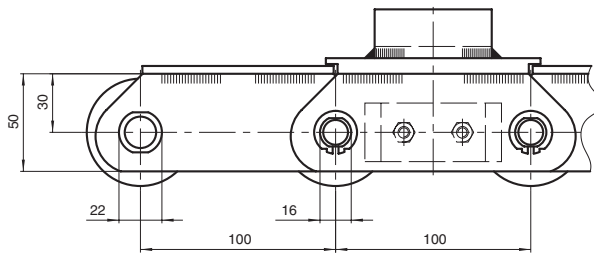

SKID
CONVEYORS

Chain P. 100x30x55 øR

 Breaking load: 120.000 N

CHAINS FOR SPECIAL APPLICATIONS – AUTOMOTIVE INDUSTRY

SKID
CONVEYORS

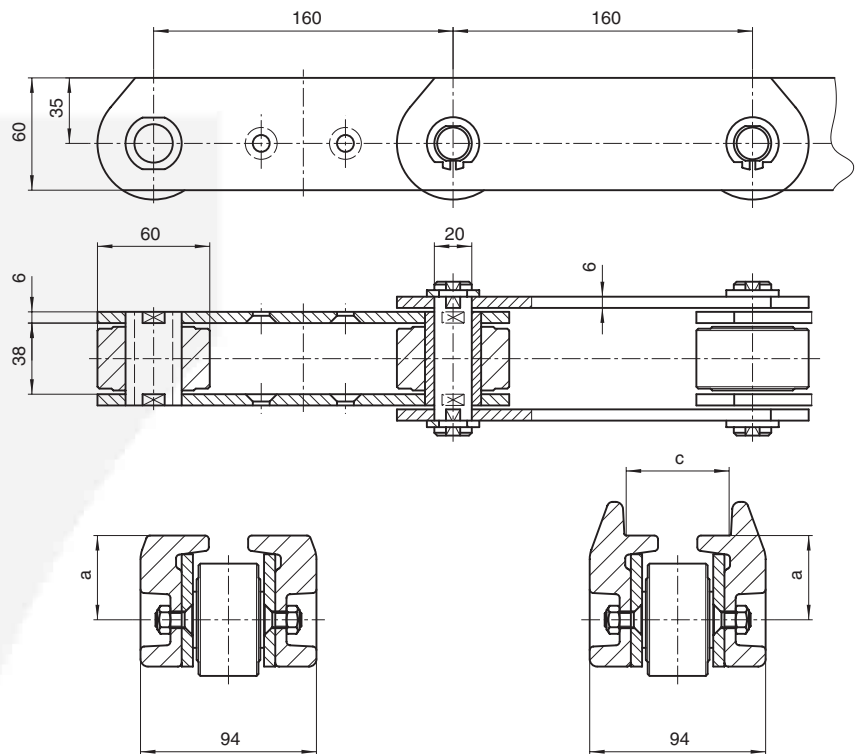

Chain P. 160x38x60 øR

 Breaking load: 200.000 N

SKID
CONVEYORS

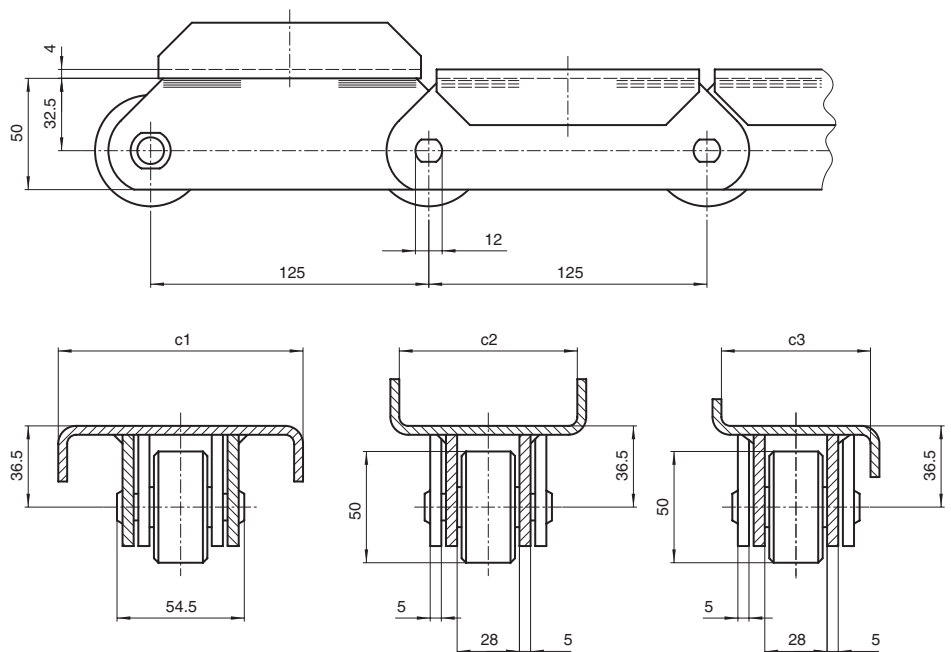

Chain P. 125x28x50 øR

 Breaking load: 80.000 N

CHAINS FOR SPECIAL APPLICATIONS – AUTOMOTIVE INDUSTRY

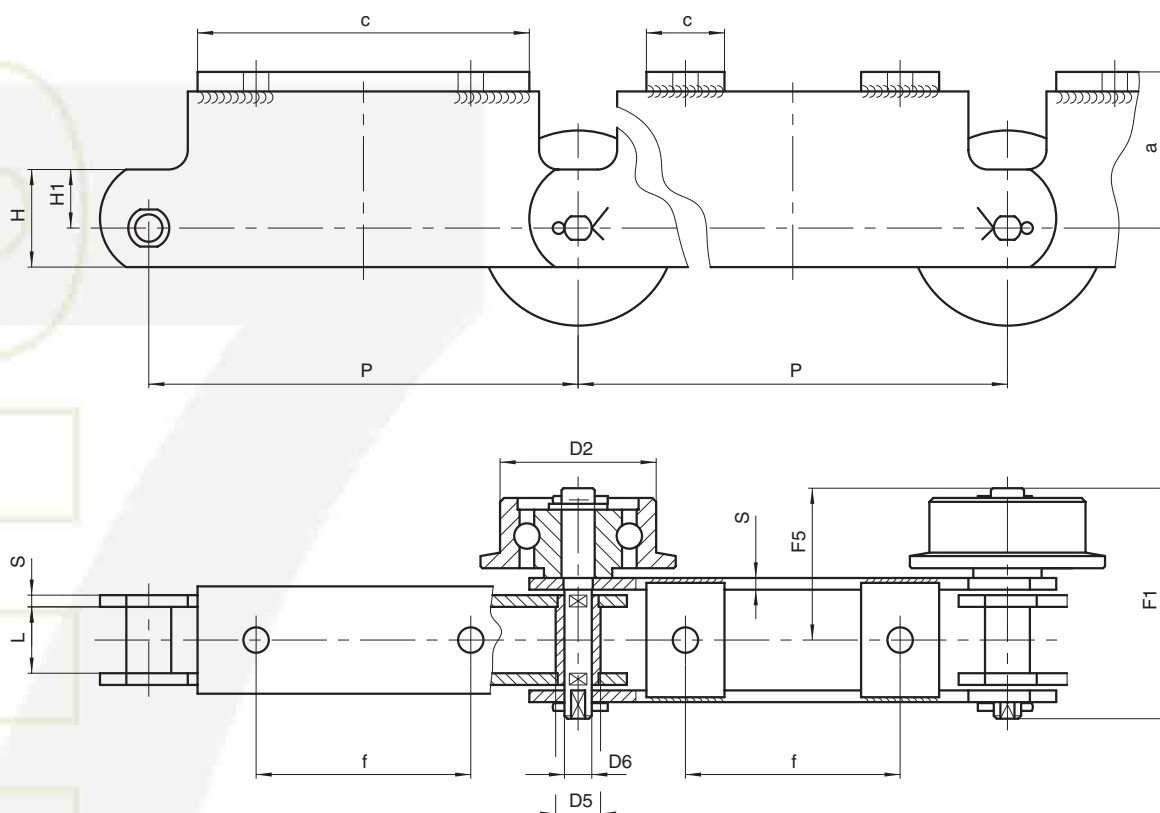

CAR CONVEYING

Chain N.	P mm	L mm	D2 mm	D5 mm	D6 mm	H mm	H1 mm	S mm	F1 mm	F5 mm	a mm	c mm	f mm	Breaking load N
W3810	220	34	80	23	14	50	31	6	114,5	76	80	170	110	140.000
W4031L	220	34	80	30	20	90	60	6	115	76	72	40	154	224.000
W4986LR	220	34	80	30	20	60	25	6	130,5	91,5	65	50	170	224.000
W4779	250	32	80	21	15	60	40	6	110,5	73,5	48	50	140	112.000
W4952	250	32	100	34	25	100	60	6	122,5	81,5	70	50	130	240.000
W4999	250	34	/	30	20	80	48	6	116	77	58	50	185	260.000
W5022	250	34	80	30	20	90	60	6	115	76	72	40	184	170.000

CHAINS FOR SPECIAL APPLICATIONS – AUTOMOTIVE INDUSTRY

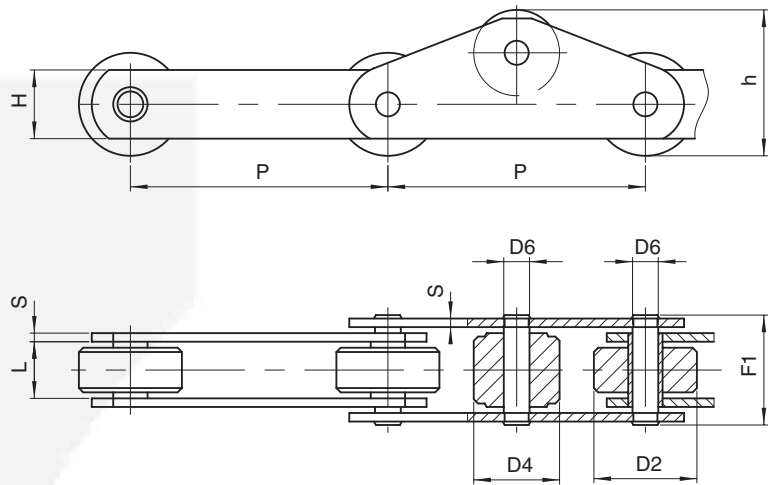

SKIDS CONVEYORS

Chain N.	P mm	L mm	D2 mm	D4 mm	D6 mm	H mm	S mm	F1 mm	h mm	 Breaking load N	Notes
W2165	50	25	20	24	10	25	4	45	32	56.000	RP every outer link
W2165A	50	25	20	24	10	/	4	45	32	56.000	RP every link
W3836A	125	28	25	42	12	35	5	54,5	53,5	80.000	RP every outer link
W1669	150	28	60	50	15	40	5	54,5	85	160.000	RP every outer link
W5165	200	50	60	60	18	50	7	85	65	160.000	RP every link

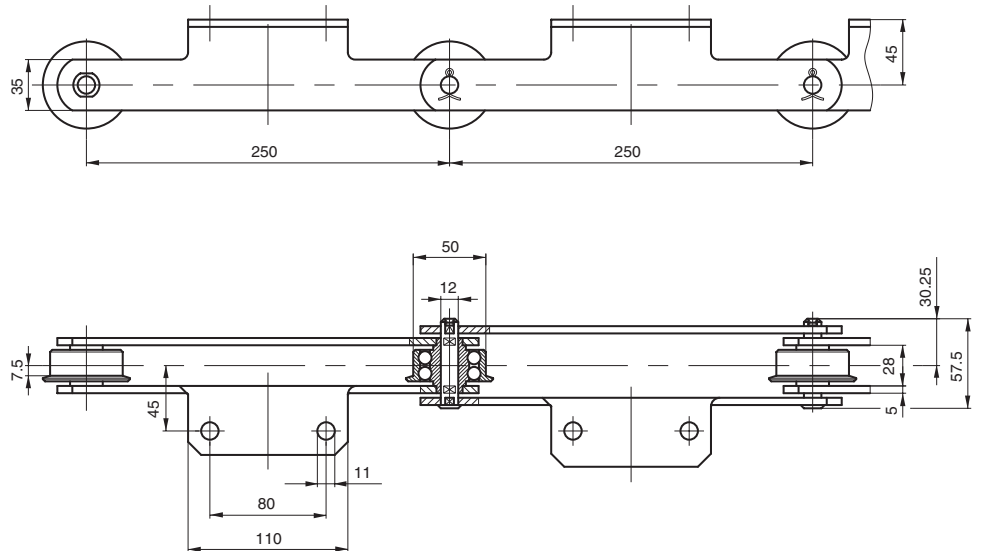

WATER TEST

Chain P. 250x28x50/60 øR

Material:
STAINLESS steel

Sealed roller bearing



Breaking load: 80.000 N



CHAINS FOR SPECIAL APPLICATIONS – AUTOMOTIVE INDUSTRY

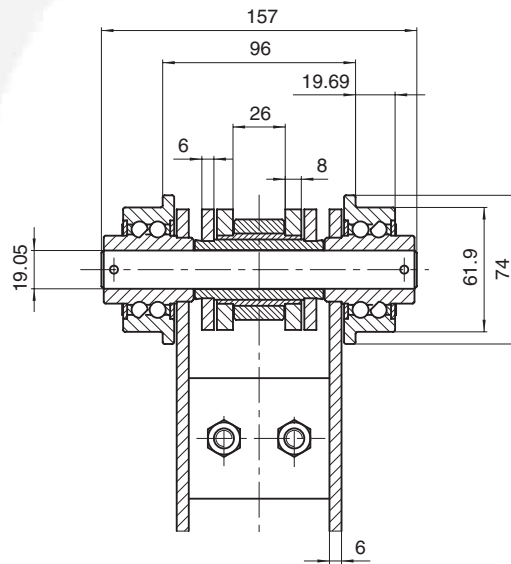
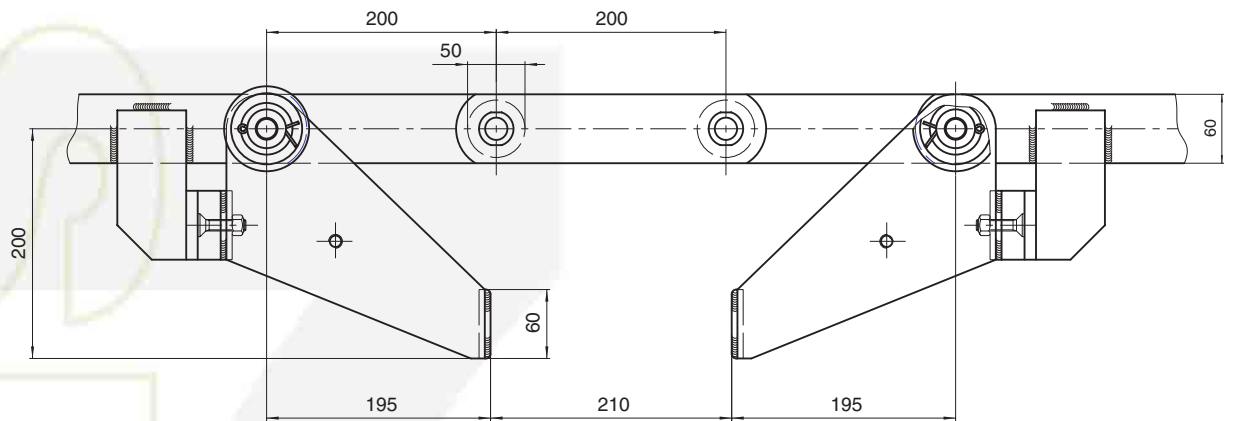

CROSS
TRANSFER
UNITS

Chain P. 200x26x60 øR



Breaking load: 300.000 N

CHAINS FOR SPECIAL APPLICATIONS – AUTOMOTIVE INDUSTRY

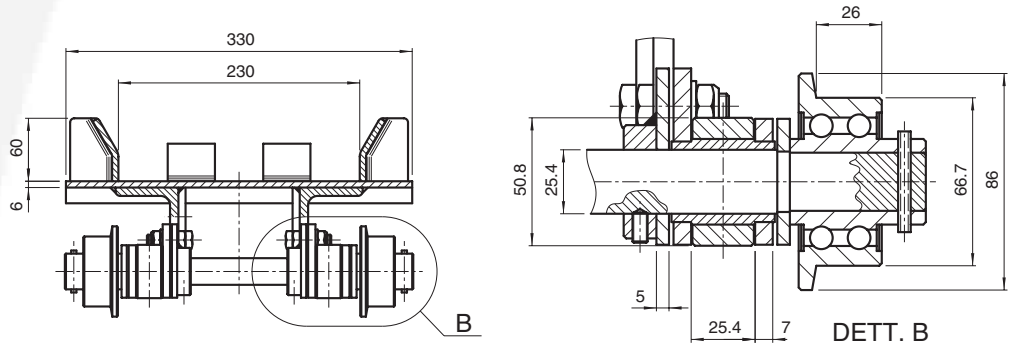
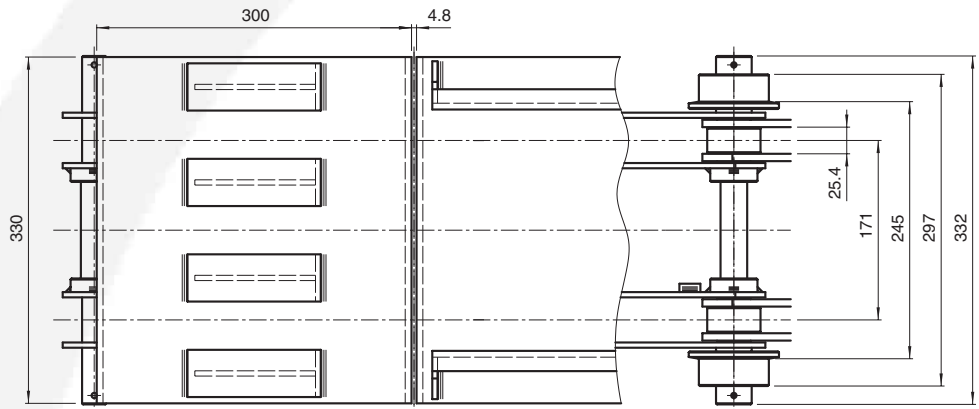
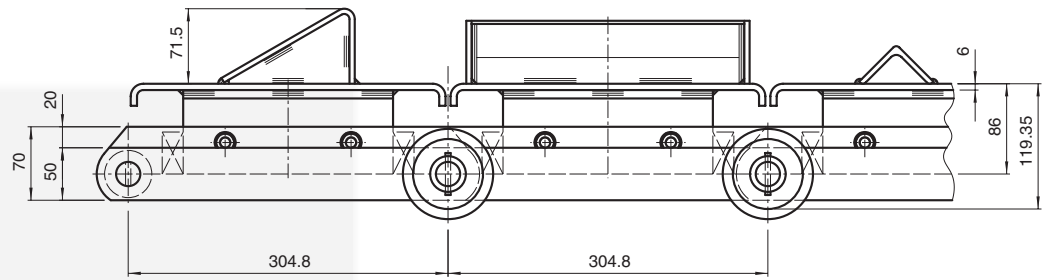

WATER TEST

Chain P. 304,8x25,4x50,8 øR

Material: treated and zinc plated steels



Breaking load: 300.000 N

